

3" ADJUSTMENT RING (AS REQ.)
WEIGHT - 145 LBS

CAST IRON RING & COVER
(PER CUSTOMER SPECS.)

48" DIA. CONCENTRIC CONE
24" HEIGHT - 1,740 LBS
30" HEIGHT - 2,175 LBS
36" HEIGHT - 2,610 LBS
42" HEIGHT - 3,045 LBS
48" HEIGHT - 3,480 LBS
60" HEIGHT - 4,350 LBS

32" DIA OPNG

48" SLAB TOP
WEIGHT - 1,550 LBS

NOTE:
48" DIA. ECCENTRIC CONE
AVAILABLE AS REQ.

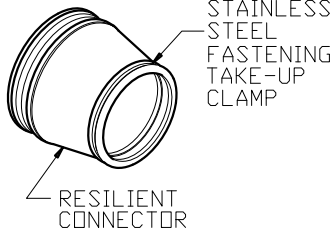
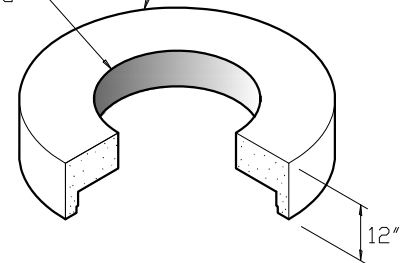
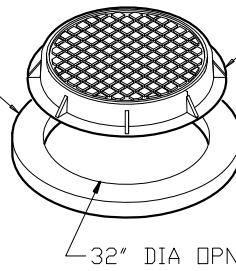
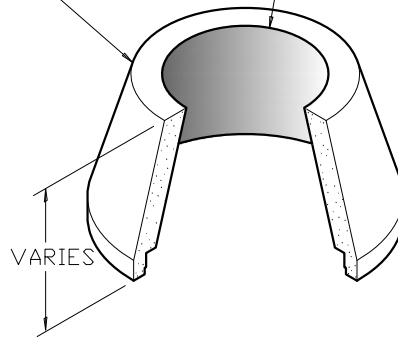

FLEXIBLE BOOT CONNECTOR
(PER ASTM C-923)

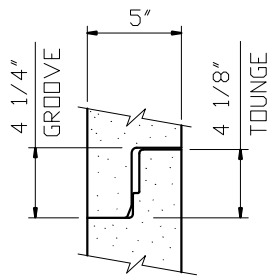

48" JOINT DETAIL

SEE 48" JOINT DETAIL

48" INSIDE DIA.

48" DIA. RISERS

12" HEIGHT - 870 LBS
18" HEIGHT - 1,305 LBS
24" HEIGHT - 1,740 LBS
36" HEIGHT - 2,610 LBS
48" HEIGHT - 3,480 LBS
60" HEIGHT - 4,350 LBS
72" HEIGHT - 5,220 LBS

5" WALL THICKNESS

VARIES

SEE 48" JOINT DETAIL

HOLE SIZE & LOCATION PER PROJECT REQUIREMENTS

SEE 48" JOINT DETAIL

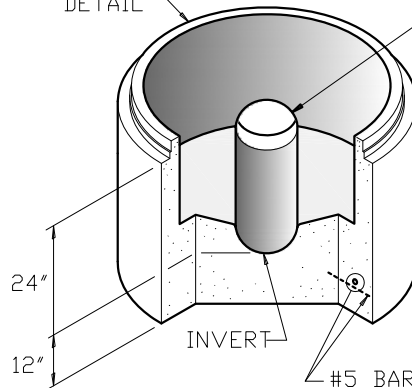

48" DIA. NC BASE

EXTENDED LIP

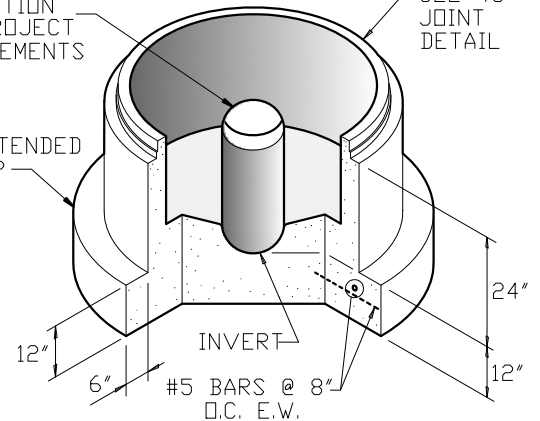

48" DIA. NC BASE WITH EXTENDED LIP

NOTE:
PLEASE REFER TO NC PIPE FOR ALL PRECAST BASE HEIGHTS AND WEIGHTS.

GENERAL NOTES:

- DESIGN SHALL MEET OR EXCEED ASTM C-478 SPECIFICATIONS
- 4500 PSI CONCRETE AT 28 DAYS
- ATSM A615, GRADE 60 REINFORCING
- HS 20 LOADING
- JOINT CONNECTIONS TO BE GASKETS CONFORMING TO ASTM C-443 REQUIREMENTS

OPTIONAL COATINGS & ADMIXTURES AVAILABLE:

- FE-100 THANE COAT
- BITUMASTIC
- XYPEX
- CONSHIELD



9235 Main Street #1
P.O. Box 507
Needville, Texas, 77461
1-888-331-5871

"Providing Concrete Environmental Solutions"

48" DIA. SANITARY
MANHOLE WITH NC BASE

NC-001-001

Scale: 1/4"=1'-0"
* All Dimensions subject to allowable specification tolerances.

Date: 02/28/18

Approved By: _____ Date: _____