

48" DIA. ECCENTRIC CONE
24" HEIGHT - 1,740 LBS
30" HEIGHT - 2,175 LBS
36" HEIGHT - 2,610 LBS

NOTE:
48" DIA. CONCENTRIC CONE & SLAB TOP AVAILABLE AS REQUIRED.

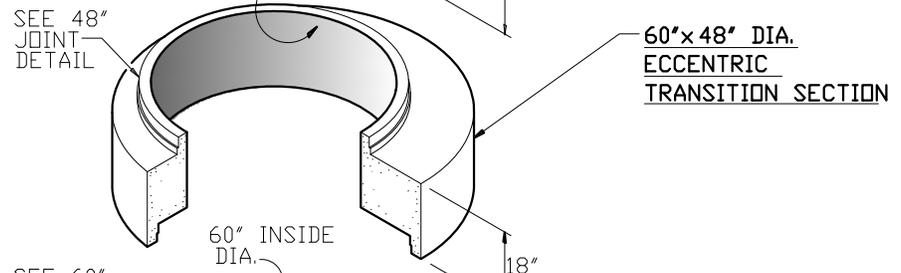
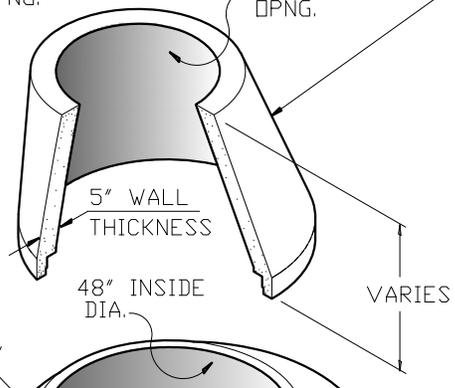
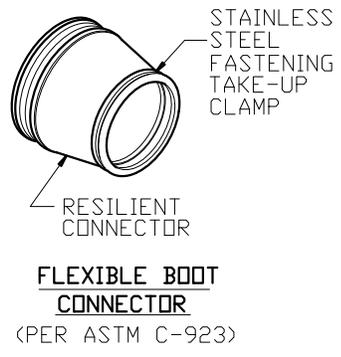

NOTE:
PLEASE REFER TO NC PIPE FOR ALL PRECAST BASE HEIGHTS AND WEIGHTS.

NOTE:
OPTIONAL EXTENDED LIP AVAILABLE PER CUSTOMER SPECIFICATIONS.

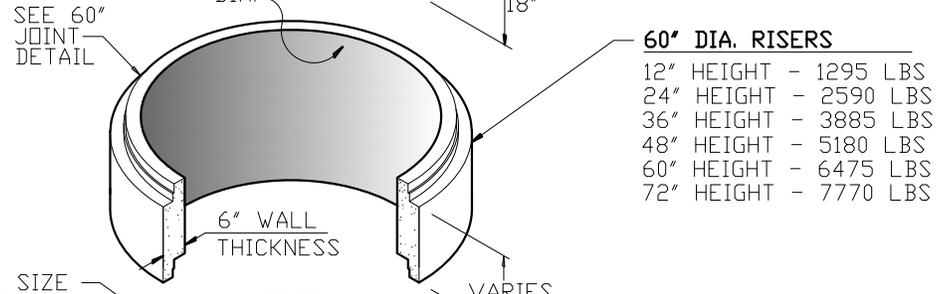

GENERAL NOTES:

- DESIGN SHALL MEET OR EXCEED ASTM C-478 SPECIFICATIONS
- 4500 PSI CONCRETE AT 28 DAYS
- ATSM A615, GRADE 60 REINFORCING
- HS 20 LOADING
- JOINT CONNECTIONS TO BE GASKETS CONFORMING TO ASTM C-443 REQUIREMENTS

OPTIONAL COATINGS & ADMIXTURES AVAILABLE:

- FE-100 THANE COAT
- BITUMASTIC
- XYPEX
- CONSHIELD

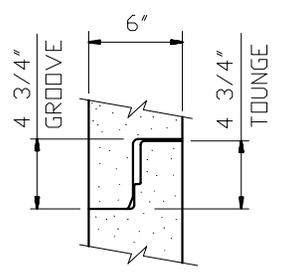
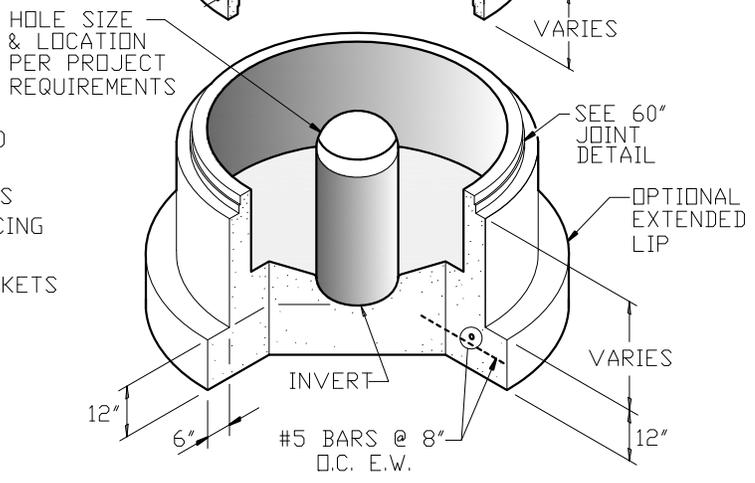

60" JOINT DETAIL

60" DIA. VARIABLE HEIGHT BASE



9235 Main Street #1
P.O. Box 507
Needville, Texas, 77461
1-888-331-5871

60"/48" DIA. ECCENTRIC
SANITARY MANHOLE

"Providing Concrete Environmental Solutions"

NC-001-008

Scale: 1/4"=1'-0"
* All Dimensions subject to allowable specification tolerances.

Date: 02/26/18

Approved By: _____ Date: _____