

72" JOINT DETAIL

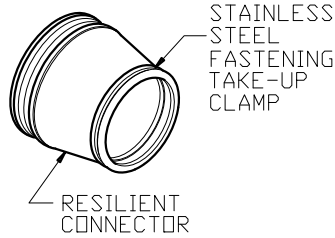

FLEXIBLE BOOT CONNECTOR
(PER ASTM C-923)

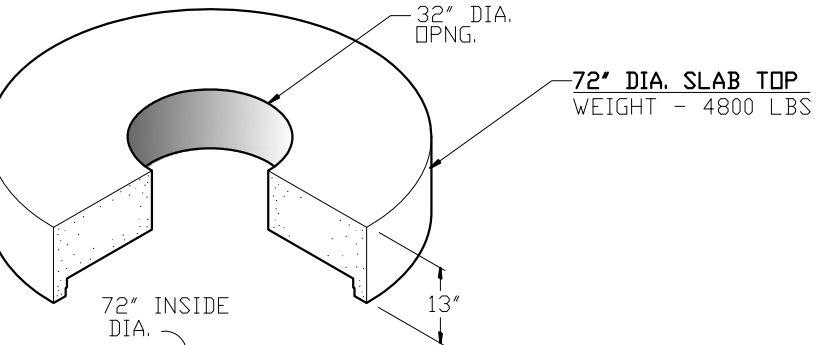
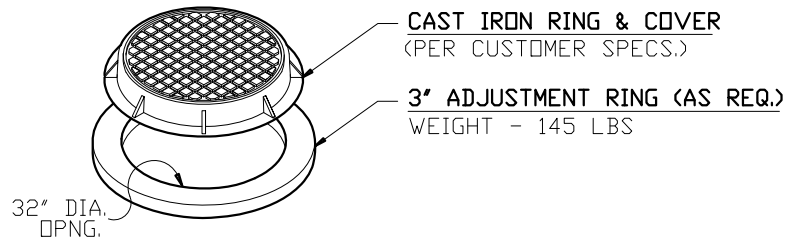
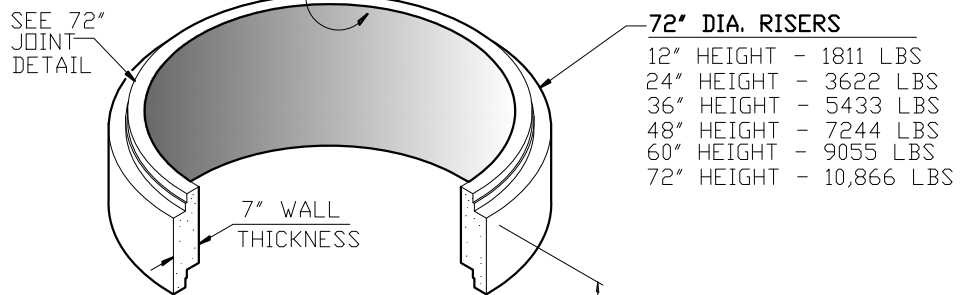

NOTE:
PLEASE REFER TO NC PIPE
FOR ALL PRECAST BASE
HEIGHTS AND WEIGHTS.

NOTE:
INVERT FOR PRECAST
BASE PROVIDED BY OTHERS.

NOTE:
OPTIONAL EXTENDED LIP
AVAILABLE PER CUSTOMER
SPECIFICATIONS.

GENERAL NOTES:

- DESIGN SHALL MEET OR EXCEED ASTM C-478 SPECIFICATIONS
- 4500 PSI CONCRETE AT 28 DAYS
- ATSM A615, GRADE 60 REINFORCING
- HS 20 LOADING
- JOINT CONNECTIONS TO BE GASKETS CONFORMING TO ASTM C-443 REQUIREMENTS

OPTIONAL COATINGS & ADMIXTURES AVAILABLE:

- FE-100 THANE COAT
- BITUMASTIC
- XYPEX
- CONSHIELD

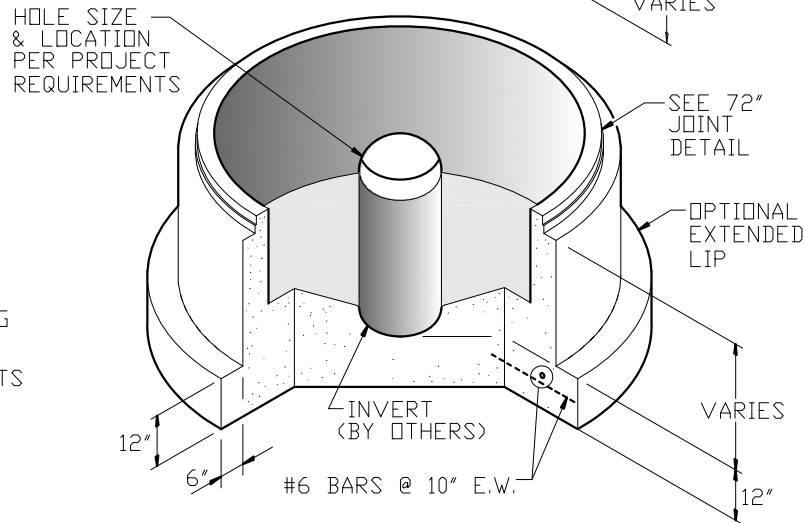

72" DIA. VARIABLE HEIGHT BASE



9235 Main Street #1
P.O. Box 507
Needville, Texas, 77461
1-888-331-5871

"Providing Concrete Environmental Solutions"

72" DIA. SLAB TOP
SANITARY MANHOLE

NC-001-010

Scale: 1/4"=1'-0"
* All Dimensions subject to allowable
specification tolerances.

Date: 02/26/18

Approved By: _____ Date: _____