

PLAN VIEW

MODEL: B-550AO
TANK - 5,075 LBS
SLAB TOP - 1,000 LBS
WEIGHT - 6,075 LBS

REINFORCEMENT (SLAB TOP)
 #3 BARS @ PERIMETER OF OPNGS
 #3 BARS @ 6" O.C.E.W.

REINFORCEMENT (BASE)
 WELDED WIRE MESH THOUGHOUT
 ALL WALLS AND FLOOR
 (.080 AREA/SQ IN)

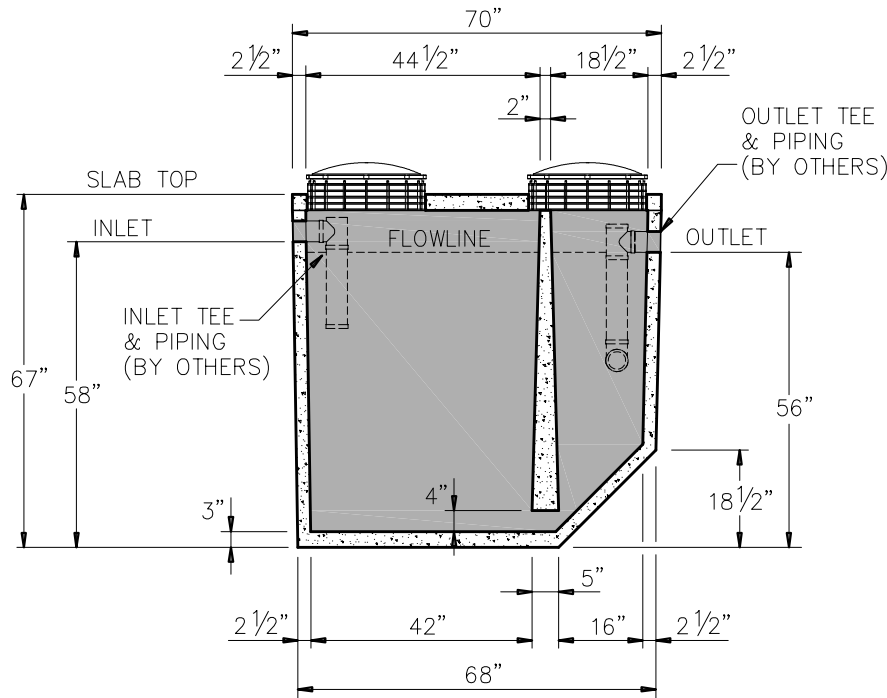

SECTION A-A

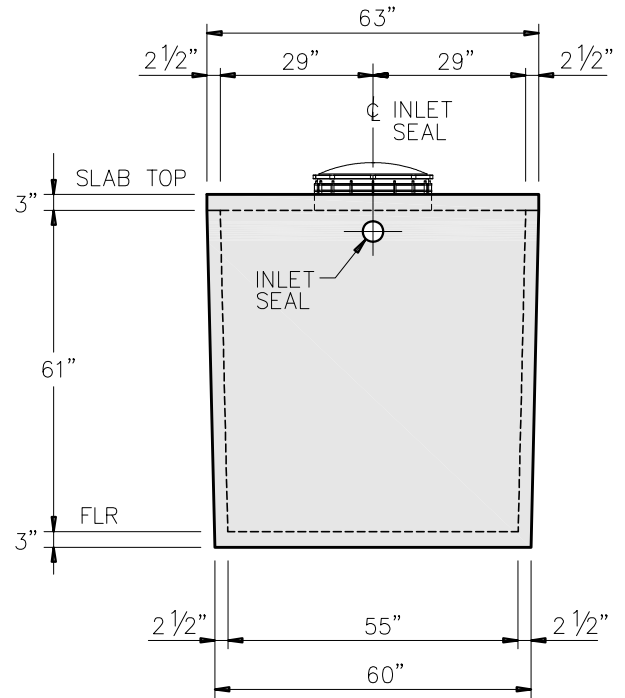

LEFT ELEVATION

GENERAL NOTES:

- DESIGN SHALL MEET OR EXCEED ASTM C-1227 SPECIFICATIONS
- 4000 PSI CONCRETE AT 28 DAYS
- ASTM A615, GRADE 60 REINFORCING
- TREATMENT CAPACITY: 600 GPD
- MAXIMUM BURIAL DEPTH TO BE 40" SLAB TOP TO GRADE
- 20" ACCESS RISER, LID & SAFETY PAN (TYP)
- ADDITIONAL RISER AVAILABLE TO BRING ACCESS TO GRADE (NOT INCLUDED)



9235 Main Street #1
 P.O. Box 507
 Needville, Texas, 77461
 1-888-331-5871

"Providing Concrete Environmental Solutions"

**NUWATER B-550 (600 GPD)
 SINGLE TANK
 AEROBIC TREATMENT UNIT
 (TANK ONLY)**

NC-008-004

Scale: N.T.S.
 * All Dimensions subject to allowable specification tolerances.

Date: 08/27/19

Rev Date: 12/09/22

Approved By: _____ Date: _____