

DETAIL 1

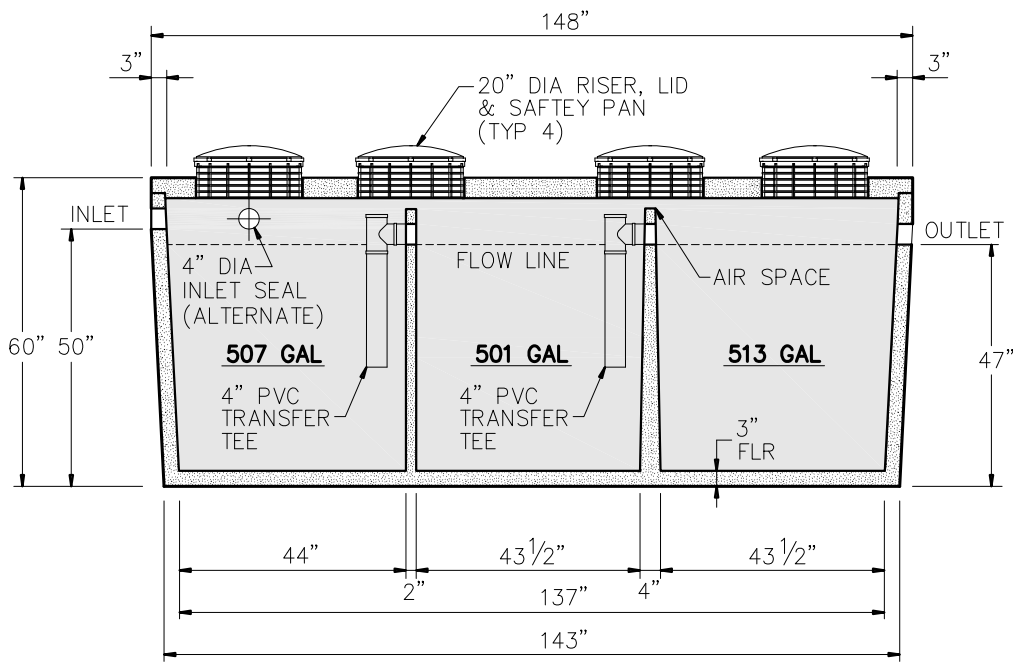

SECTION A-A

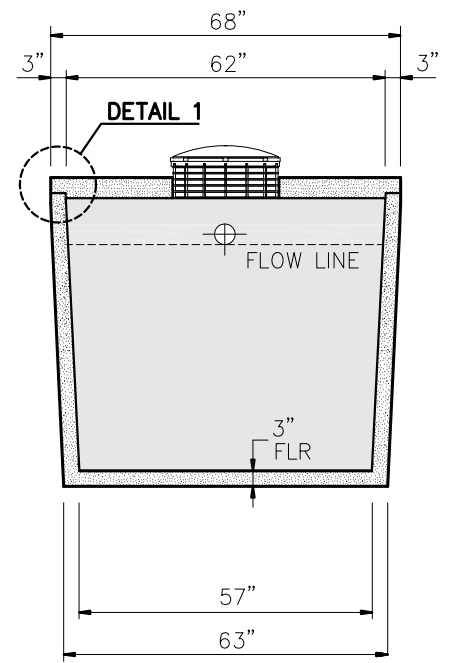

SECTION B-B

GENERAL NOTES:

- DESIGN SHALL MEET OR EXCEED EXCEED ASTM C-1227 SPECIFICATIONS
- 4000 PSI CONCRETE AT 28 DAYS
- ASTM A615, GRADE 60 REINFORCING
- BAR BENDING AND PLACEMENT PER ACI STANDARDS

NOTE:

APPROX WEIGHTS INCLUDING SLAB TOP & BOTTOM SECTION
WEIGHT - 12,000 LBS
CAPACITY - 1521 GAL



"Providing Concrete Environmental Solutions"

9235 Main Street #1
P.O. Box 507
Needville, Texas, 77461
1-888-331-5871

1500 GALLON
3-COMPARTMENT
SEPTIC TANK

NC-004-012

Scale: 1/4"=1'-0"
* All Dimensions subject to allowable specification tolerances.

Date: 04/01/19

Rev Date:

Approved By: _____ Date: _____