

**PLAN VIEW**

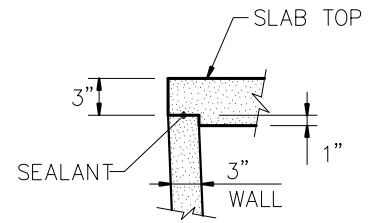

**DETAIL 1**

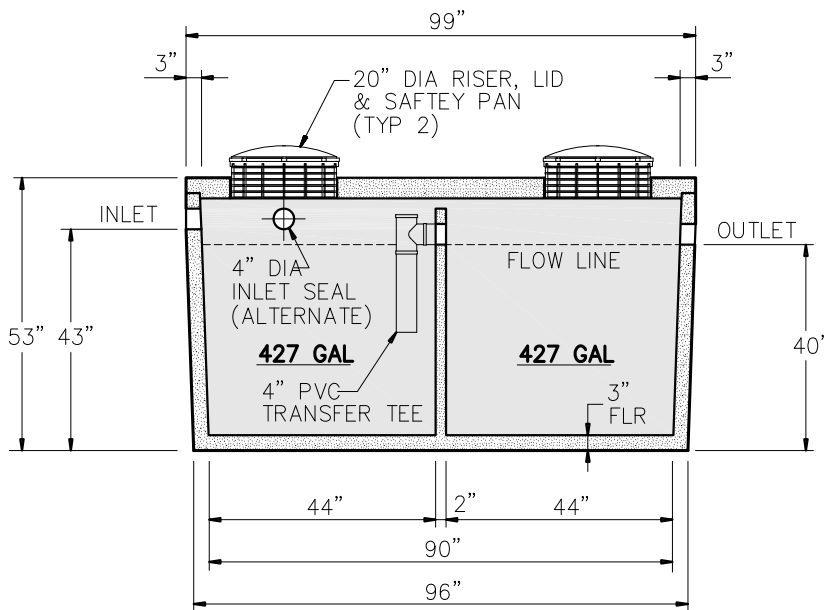

**SECTION A-A**

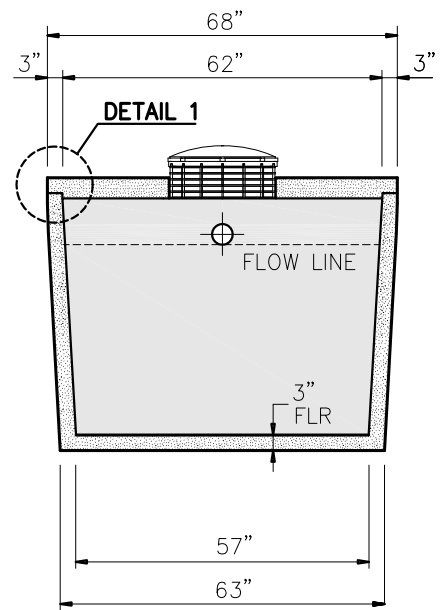

**SECTION B-B**

**GENERAL NOTES:**

- DESIGN SHALL MEET OR EXCEED EXCEED ASTM C-1227 SPECIFICATIONS
- 4000 PSI CONCRETE AT 28 DAYS
- ASTM A615, GRADE 60 REINFORCING
- BAR BENDING AND PLACEMENT PER ACI STANDARDS

**NOTE:**

APPROX WEIGHTS INCLUDING SLAB TOP & BOTTOM SECTION  
 WEIGHT - 7500 LBS  
 CAPACITY - 854 GAL



"Providing Concrete Environmental Solutions"

9235 Main Street #1  
 P.O. Box 507  
 Needville, Texas, 77461  
 1-888-331-5871

**750 GALLON  
 2-COMPARTMENT  
 SEPTIC TANK**

NC-004-020

Scale: 1/4"=1'-0"  
 \* All Dimensions subject to allowable specification tolerances.

Date: 04/09/19

Rev Date:

Approved By: \_\_\_\_\_ Date: \_\_\_\_\_